

PERMA-COLUMN®

WWW.PERMACOLUMN.COM



Deliver



Place



Set Column



Attach Splash Board



— “THE PERMANENT SOLUTION” —

Why should you have to choose between a foundation that is **economical** and one that is **permanent**? PERMA-COLUMNS® are the first product to combine the economy and speed of post-frame construction with the durability of a concrete foundation.

Proven - Concrete is the most proven and durable foundation material known to man!

Economical - PERMA-COLUMNS are the most economical method of constructing a post-frame building on concrete!

Safe - PERMA-COLUMNS are safe and have no harsh chemicals or preservatives like treated wood!

A building is only as permanent as the foundation on which it is built.

What are YOU building on?

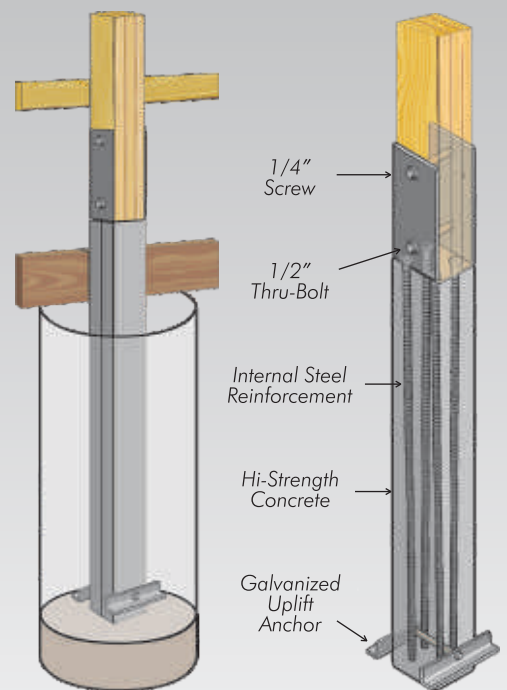

phone: 1-800-622-7190
sales@permacolumn.com

I. REVOLUTIONARY DESIGN

- ◆ PERMA-COLUMNS are the first product to combine the economy of post-frame construction with the durability of a concrete foundation.
- ◆ The exclusive design of the PERMA-COLUMN is patented.

II. TECHNICAL SPECIFICATIONS

- ◆ The latest in SCC pre-casting technology creates a product with three times the strength of regular concrete.
- ◆ Polymer fiber reinforcement and premium grade steel reinforcement dramatically enhance flexural strength.
- ◆ Corrosion inhibitors protect internal steel reinforcement.
- ◆ Air entraining admixtures insure resistance to harsh freeze-thaw cycles.

III. INVESTMENT SECURITY

- ◆ PERMA-COLUMNS keep wood out of the ground ensuring that your building's foundation will never rot.
- ◆ PERMA-COLUMNS protect your building investment by securing its value for a lifetime.

IV. ENVIRONMENTAL SAFETY

- ◆ PERMA-COLUMNS do not use the harsh chemicals found in treated lumber, which are being phased out by the EPA.
- ◆ Using an environmentally friendly product promotes peace of mind.

V. STRENGTH DATA

- ◆ PERMA-COLUMNS have been tested by The University of Wisconsin. Design manuals are available by request.
- ◆ In comparative strength tests performed by Purdue University, PERMA-COLUMNS have proven to outperform the industry standard.

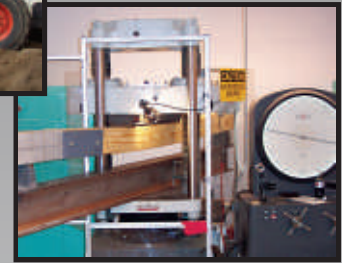
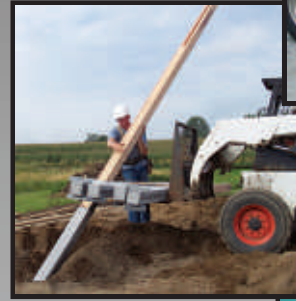

Comparative Test Results

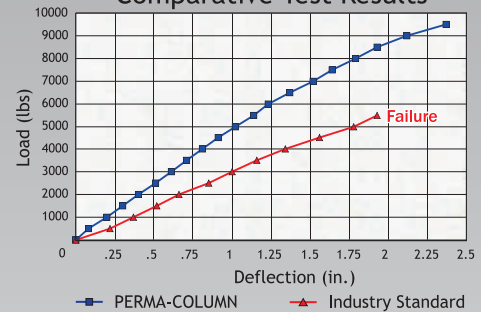

6 MODELS TO MEET YOUR NEEDS

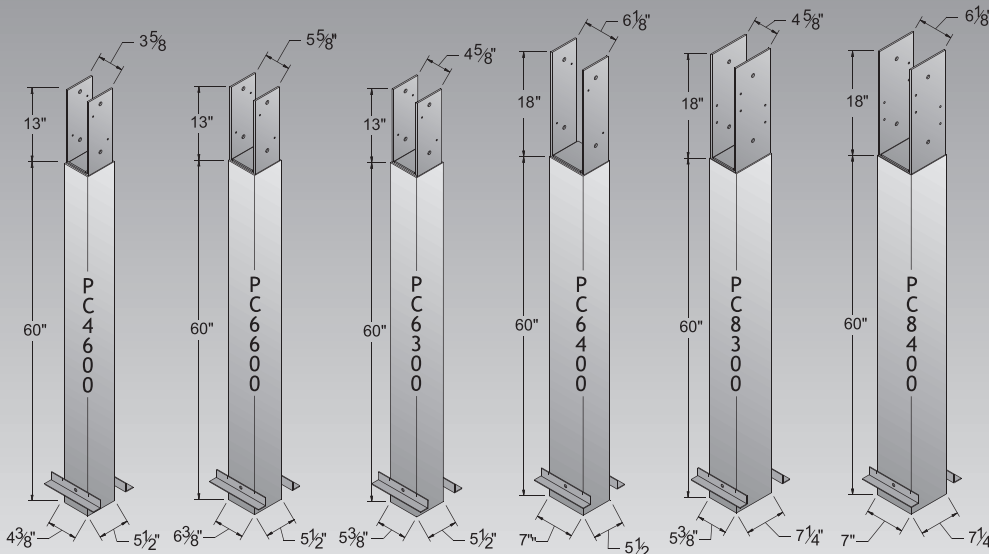

- PC4600 - for use in 4" X 6" wood post replacement
- PC6600 - for use in 6" X 6" wood post replacement
- PC6300 - for a 3 ply 2" X 6" laminated wood column
- PC6400 - for a 4 ply 2" X 6" laminated wood column
- PC8300 - for a 3 ply 2" X 8" laminated wood column
- PC8400 - for a 4 ply 2" X 8" laminated wood column

*Consult a design professional for appropriate model.

